



## GENERAL SPECIFICATIONS

Car Size: 32" x 48" x 75 1/4" (10.7 ft<sup>2</sup>)

Rated Load: 500 lbs. (227kg)

Rated Speed: 20 fpm (0.1 mps)

Travel: 16' maximum (4.9m)

Power Supply: 115 VAC, 60 Hz, 20 AMP

Motor: 3/4 hp, 110 VAC, 60 Hz, single phase

Drive: 80:1 reduction helical worm gear

Controls: Automatic push button car and landing control buttons

Interior Finish: Wall panels - White or paintable laminate panels

Ceiling - White or paintable laminate panel

Floor - Steel floor with Ivory powder coat

Lighting - Surface mounted light with on-off switch

Doors: White accordion car gate

Two Access Electric Strike Interlocks provided for hoistway doors (doors by others)

Other Standard Features: Telephone jack

Manual lowering device

Final and ultimate limit switches

Car gate safety switch

Slack rope safety

Pit stop switch

Car top stop switch

Final limits (2 upper, 1 lower)

Emergency stop button in car with audible alarm

31" wide threshold ramp

Optional Features: Handrail

Recessed telephone cabinet (brushed stainless steel or bronze cover)

Light oak laminate car panels

Keyed controls

## HOISTWAY PLAN

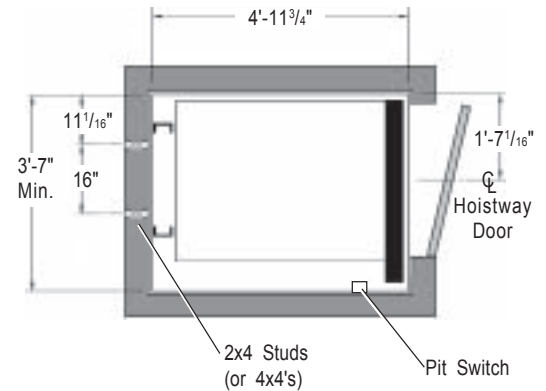

Dimensions are to inside finished walls.

Left hand car shown, right hand car opposite.

## HOISTWAY ELEVATION

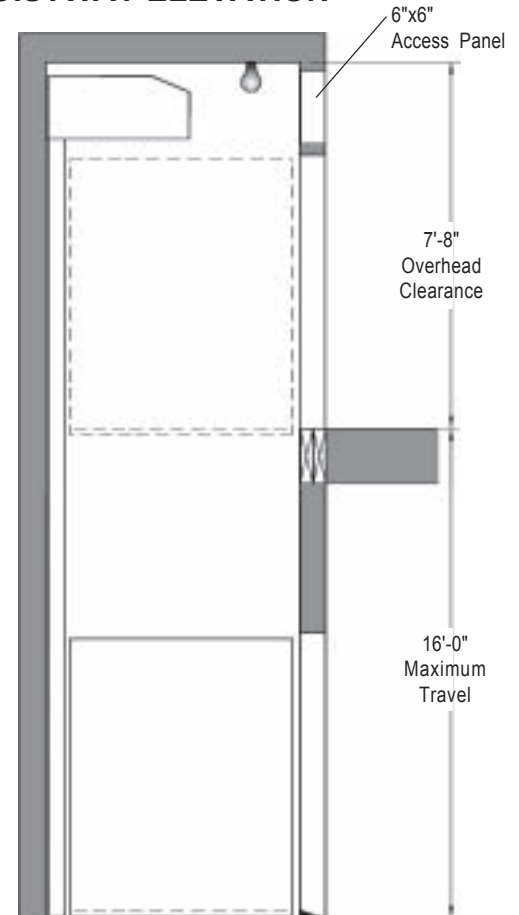

Dimensions and specifications are subject to constant change (without notice) due to continually evolving codes and product applications.

Elevator configurations and dimensions are in accordance with Access Industries' interpretation of the standards set forth by ASME and the ADA. Please consult Access Industries for more specific information pertaining to your project, including any deviation between referenced standards and those of any local codes or laws.

All dimensions, illustrations and specifications comply with product design as of date of publication and are subject to change without notice.

XXIM1203-370